

Double Spindle
Double Turret
Triple Channel

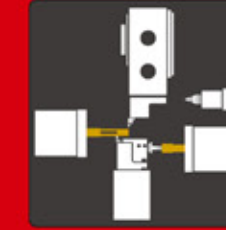

MTY 51
MTY 65

-  Aerospace
-  Automotive
-  Electronics
-  Hydraulics
-  Medical
-  Pneumatics



TEL: +886-4-2537-7564 FAX: +886-4-2537-1959
www.mylascnc.com sales@mym.com.tw

Renewed Partnerships
Refined Machines

MTY SERIES

MY-TURN MTY51/65



With tailstock, the Max. machining length can be 5 times of diameter.



Compound machining, save up to 10% of cycle time

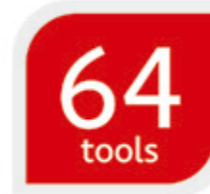

The Max. tool numbers is 64 tools.



The Max. pressure of tooling can be 70 bar.

High Speed

Adopt linear guideway to achieve the fastest movement, X axis rapid traverse 24 mm/min, Z axis rapid traverse 36 mm/min, Y axis rapid traverse 18 mm/min

High Rigidity

Monoblock casting construction to ensure the highest rigidity



KEY FEATURES

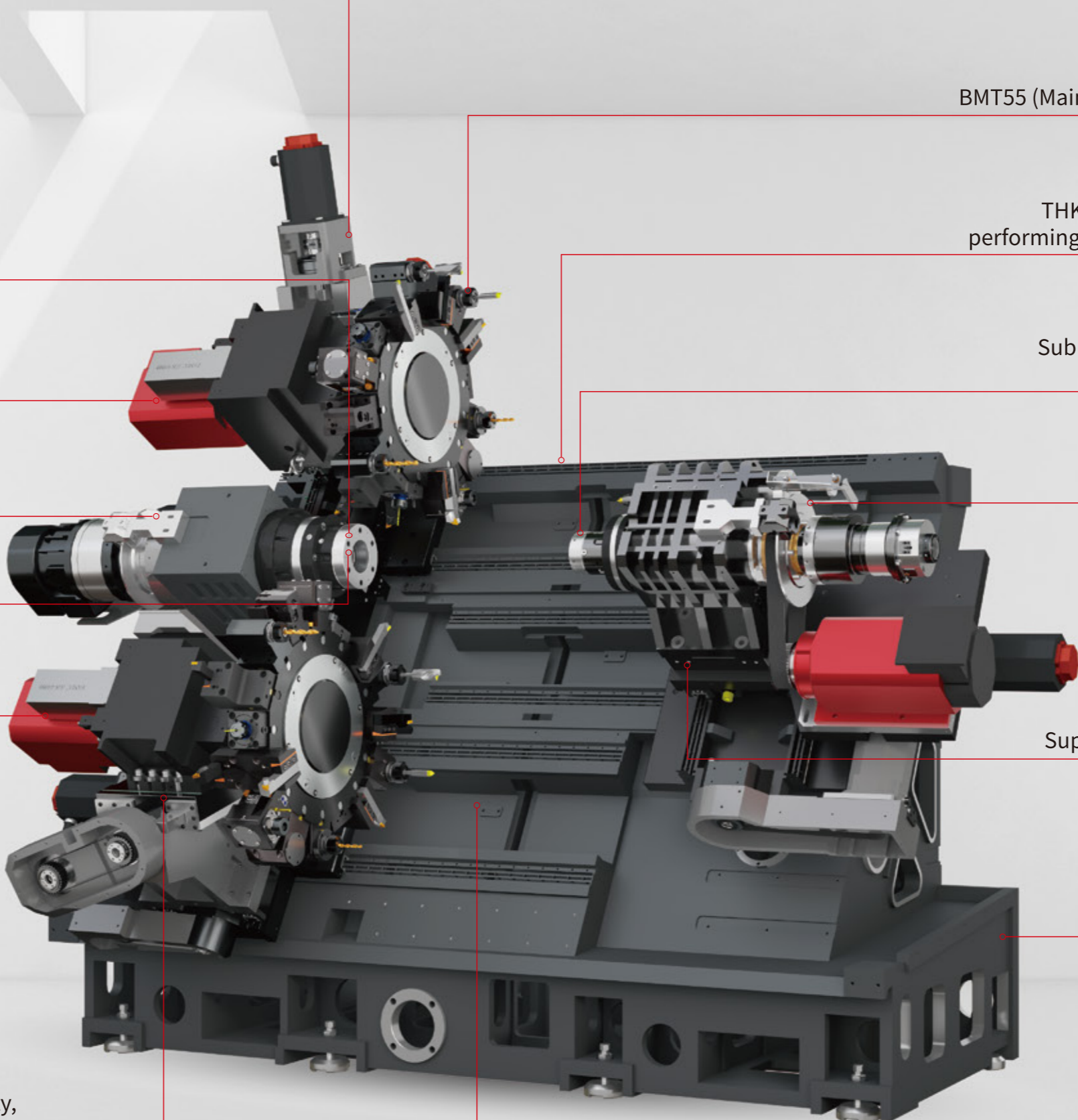

Boxed way Y axis ensure the highest rigidity,
Y axis travel $\pm 45\text{mm}$

BMT55 (Main/Sub) live turret with 16 stations

THK ball guideway with 6 pcs blocks,
performing the highest accuracy and rigidity

Sub spindle max. bar dia. 51mm with
motor power 5.5 / 7.5 kW

Hydraulic brake with C axis
with guaranteed accuracy

Superimposition machining function

High rigidity
monoblock construction

THK double screwnut ballscrew with highest rigidity

Main spindle
spindle nose A2-5 with higher speed

Milling power 3.7 / 5.5 kW

Hydraulic brake with C axis with
guaranteed accuracy

Main spindle max. bar dia. 65mm
with motor power 7.5 / 11 kW

Milling power 3.7 / 5.5 kW

Boxed way Y axis ensure the highest rigidity,
Y axis travel $\pm 45\text{mm}$

CONFIGURATION

A

- Double channel
- Single Y axis

B

- Double channel
- Single Y axis
- Tailstock

C

- Double channel
- Double Y axis

D

- Double channel
- Double Y axis
- Tailstock

E

- Triple channel
- Double Y axis
- Tailstock

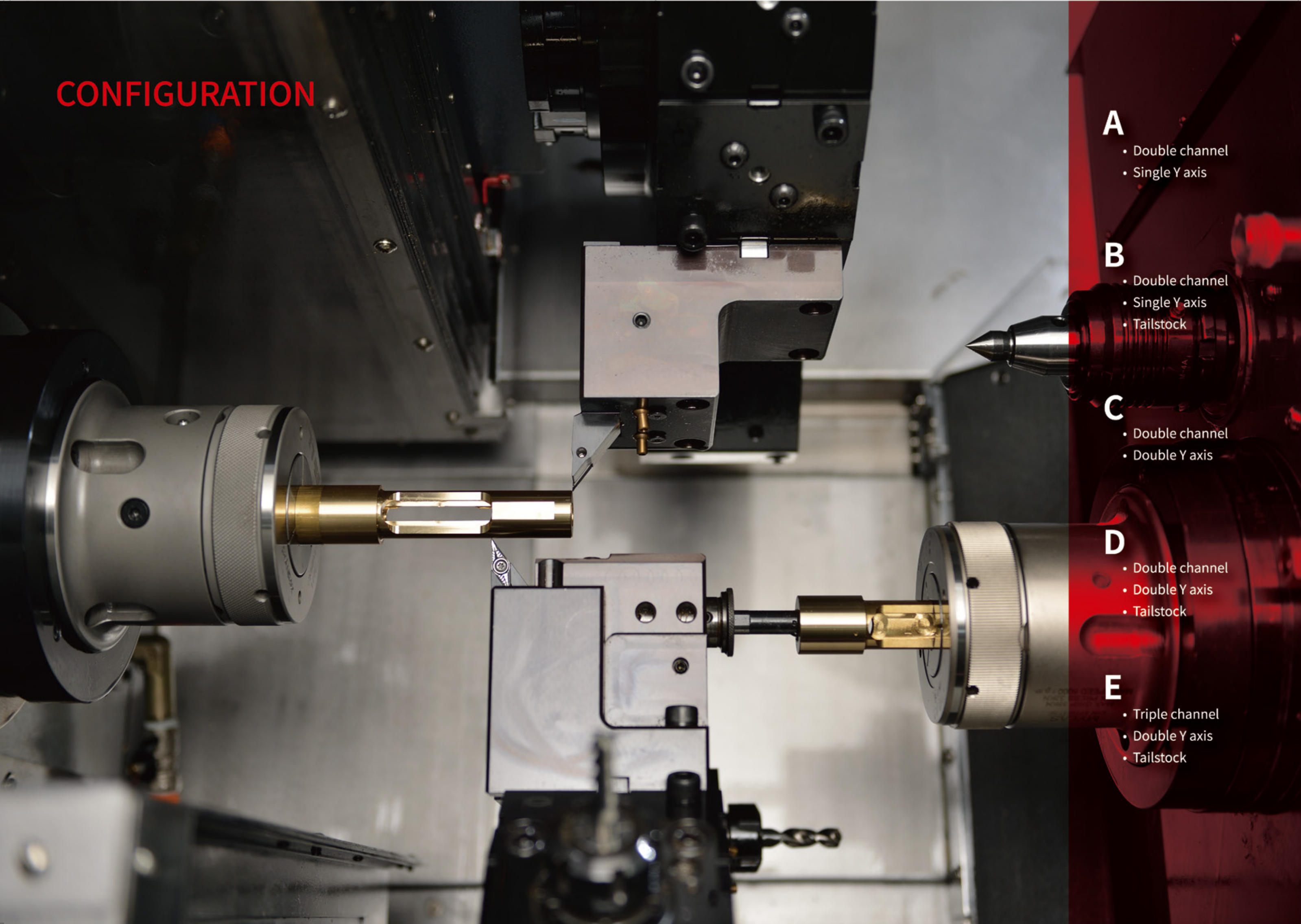

MACHINING EXAMPLE

1 The large travel of the sub-spindle allows simultaneous working with 3 tools in varied conditions.

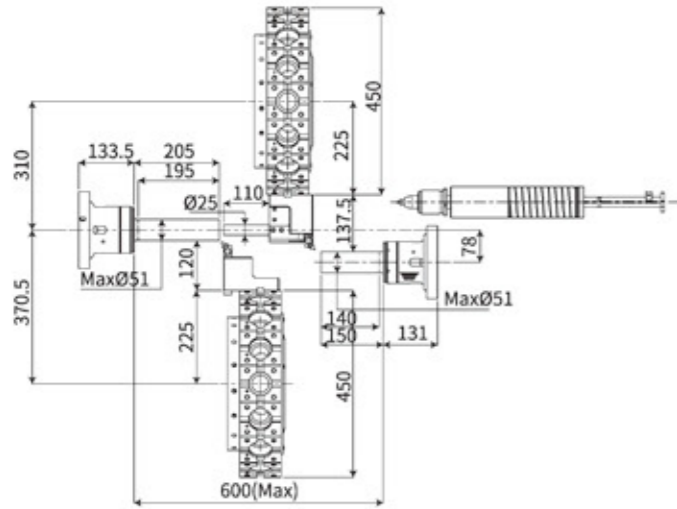

2 The third CNC channel gives the flexibility to program multiple applications using 3 tools simultaneously.

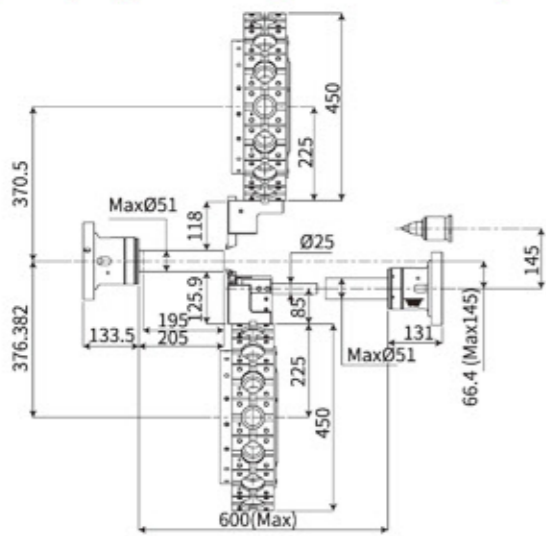

3 The machine can finish the part in the sub-spindle while machining continues between main spindle and tailstock.

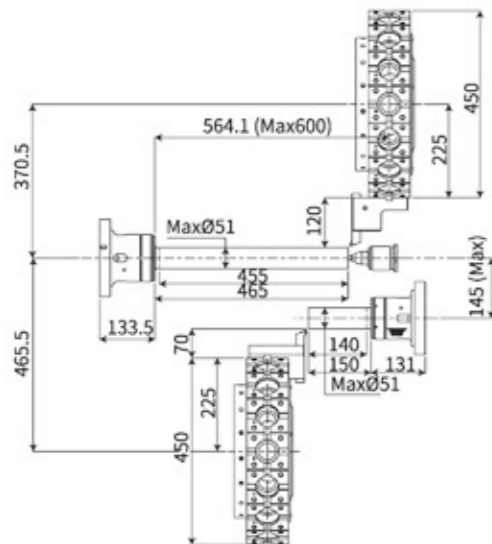

4 Drill simultaneously using the 2 spindles without programming limitations.

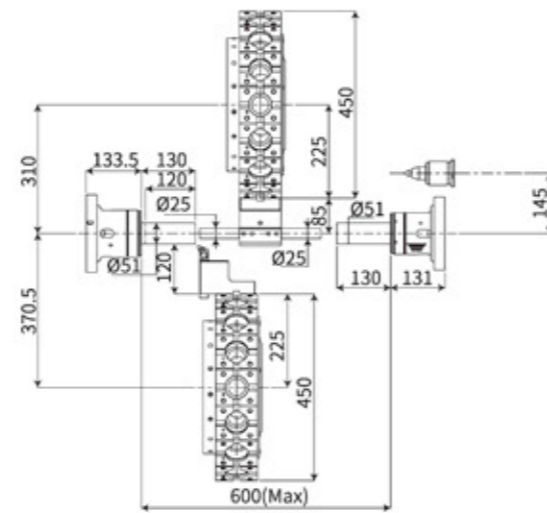

5 Any shape can be turned in the sub-spindle, while the same turret works on the main spindle.

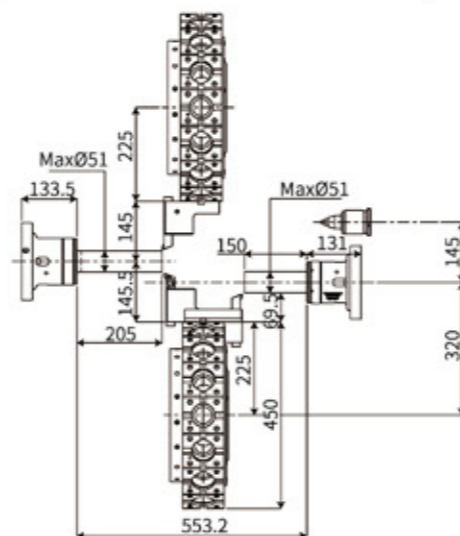

6 Balanced cutting reduces vibration, allowing increased material removal.

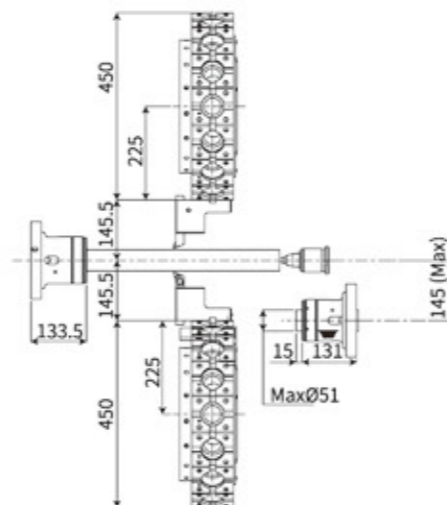

MACHINING CAPACITY

180

The Max. diameter of single-part feeding is 180 mm.

5

The Max. length is 5 times of diameter with tailstock.

10%

With Max. 3 channels simultaneously machining, the total cycle time can be Save Up to 10% than double channel machining.

51

The Max. diameter of main spindle in MTY51 is 51 mm.

65

The Max. diameter of main spindle in MTY65 is 65 mm.

42

The Max. diameter of sub spindle in both model is 42 mm.

MAIN SPINDLE

- Extremely rigid main and sub-spindles with purpose built roller bearings on the front and rear to concentrate power directly to the cutting surface and resist axial and radial forces.
- Higher speeds and heavy-cuts are possible with this bearing arrangement.
- Simultaneous independent machining of the workpiece and C-axis with resolution of 0.001 degrees allows for complex contouring of parts.

SPINDLE SPEED:

4000 rpm (MTY65)
5500 rpm (MTY51)

SPINDLE POWER:

7.5 / 11 kW

SPINDLE NOSE:

A2-6 (MTY65)
A2-5 (MTY51)

BEARING:

NN type bearing

HOLE THROUGH SPINDLE:

Ø79 mm (MTY65)
Ø62 mm (MTY51)



SUB SPINDLE

SPINDLE SPEED:

6000 rpm

SPINDLE POWER:

5.5 / 7.5 kW

SPINDLE NOSE:

A2-5

HOLE THROUGH SPINDLE:

Ø55 mm

Special construction without the tube inside
Accumulated interference decrease space

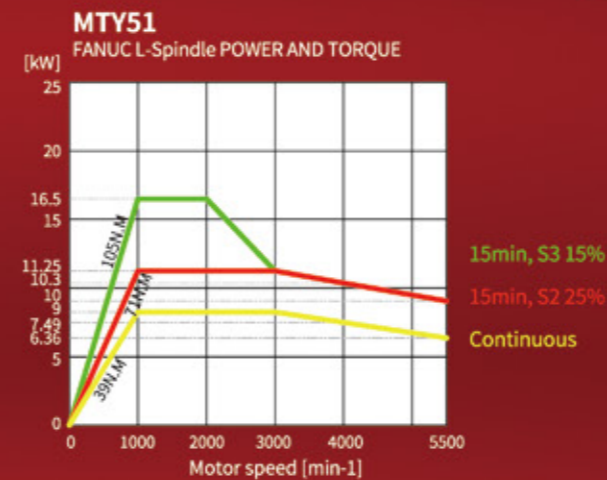
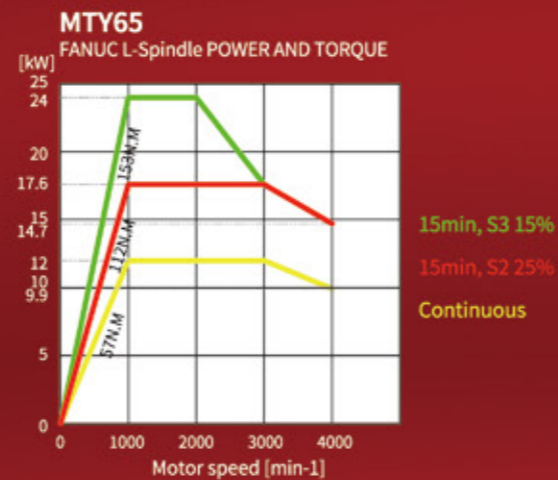
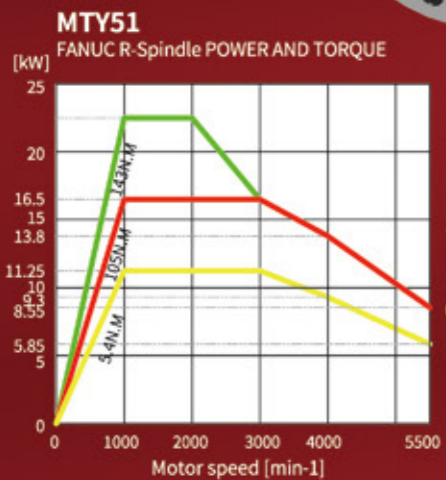

TAILSTOCK TRAVEL:

100 mm
Max. turning length is 5 times of diameter with tailstock

TURRET

64

Max. tool number
64 tools

3.7 / 5.5
kW

Live tooling motor

2

Turret

16

Stations

55

BMT

6000

Rating speed
6000 rpm

0.16

Indexing time
0.16 secs

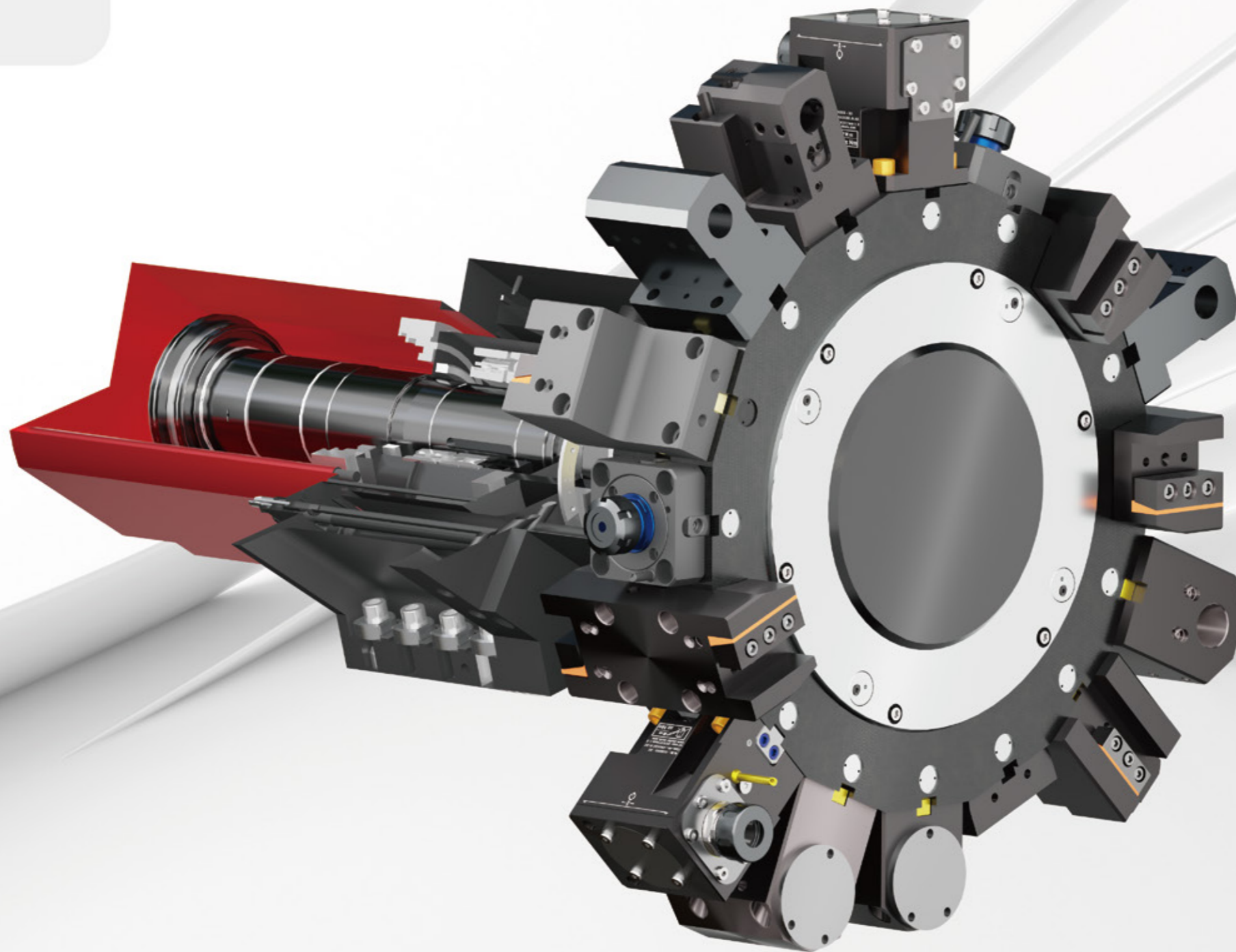

TOOL HOLDERS

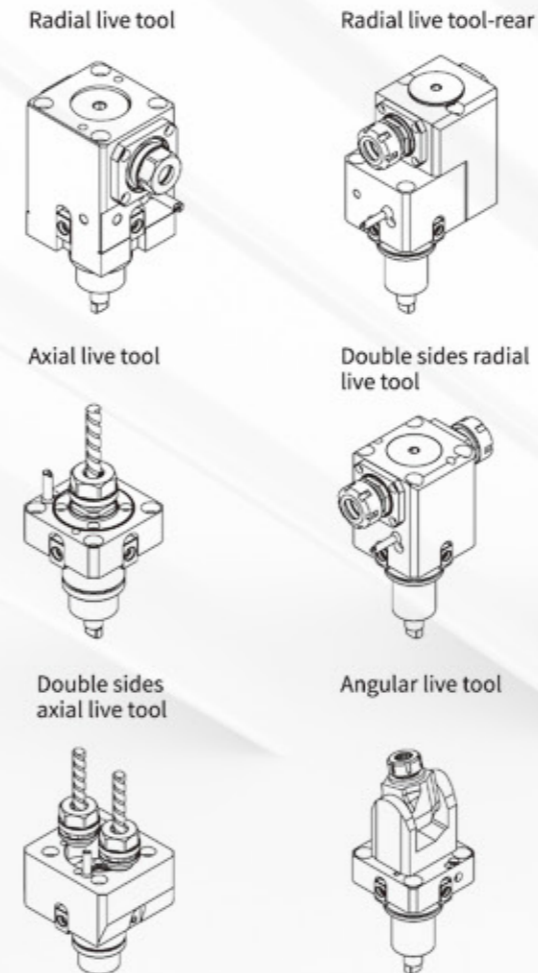
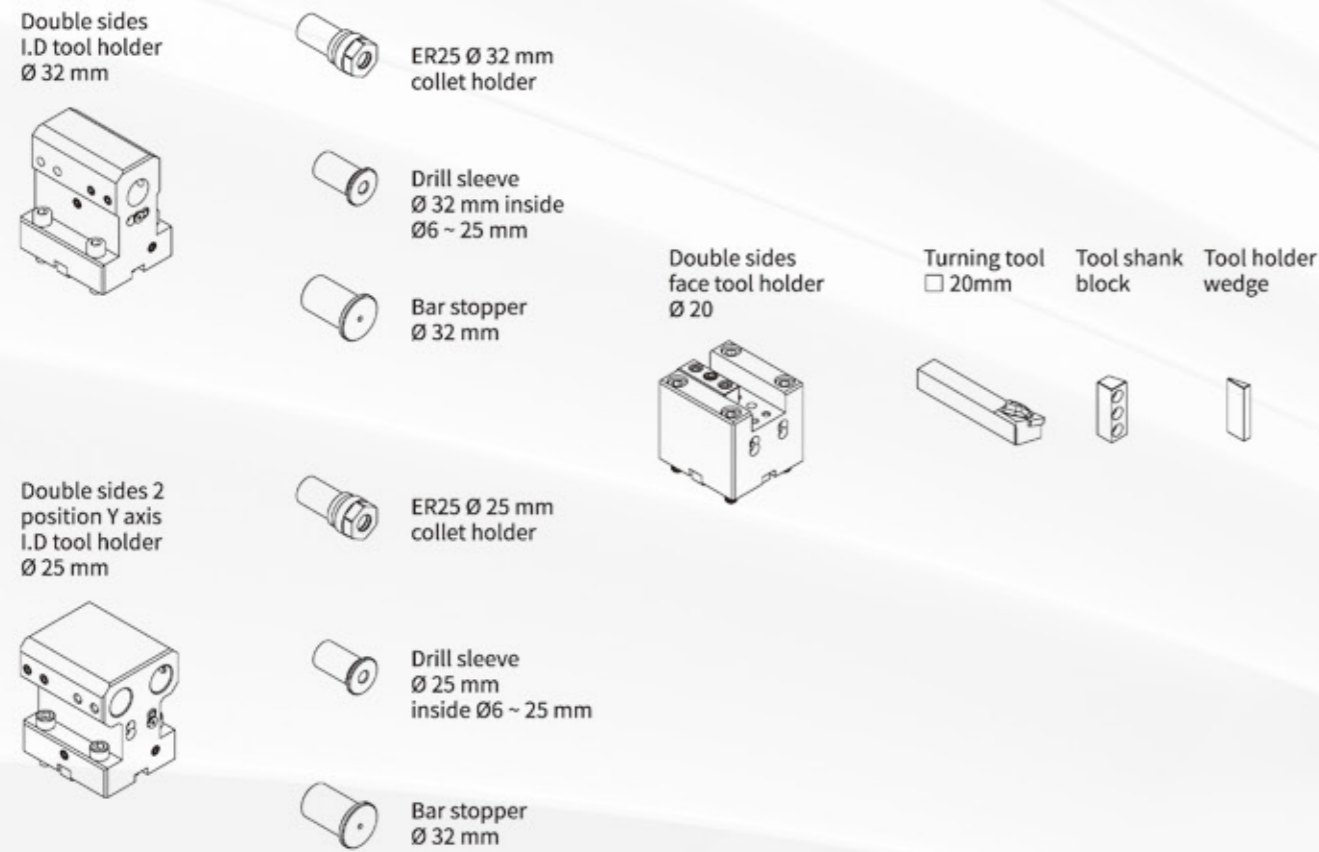
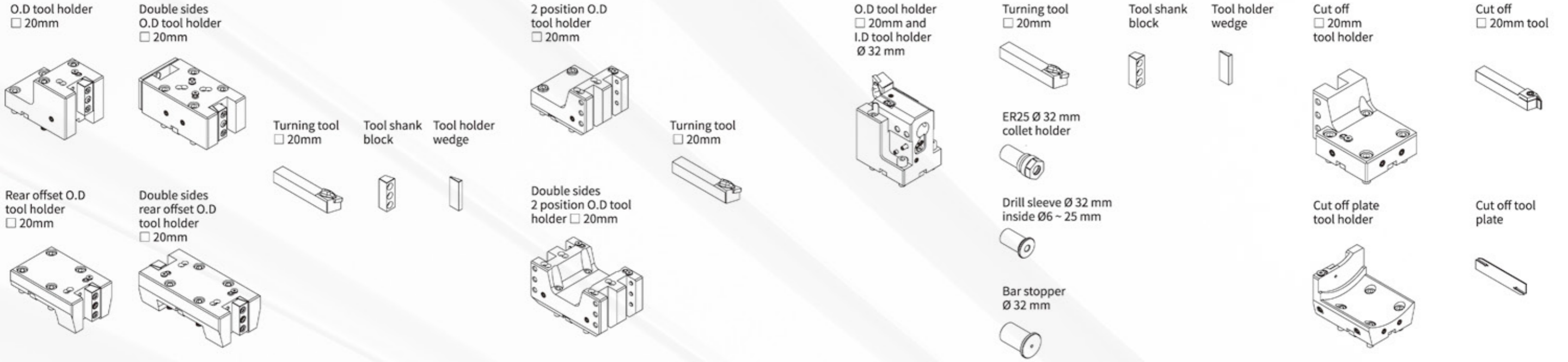

SPECIFICATIONS

	ITEM	Unit	51A	65A	51B	65B	51C	65C	51D	65D	51E	65E
Main spindle	Chuck dia	mm	6"	8"	6"	8"	6"	8"	6"	8"	6"	8"
	Max.turning diameter	mm	180	180	180	180	180	180	180	180	180	180
	Max.turning bar diameter	mm	51	65	51	65	51	65	51	65	51	65
	Spindle nose	type	A2-5	A2-6	A2-5	A2-6	A2-5	A2-6	A2-5	A2-6	A2-5	A2-6
	Hole trough spindle	mm	62	79	62	79	62	79	62	79	62	79
	Spindle speed	rpm	5500	4000	5500	4000	5500	4000	5500	4000	5500	4000
	Spindle motor (cont / 30 min)	kw	7.5/11	7.5/11	7.5/11	7.5/11	7.5/11	7.5/11	7.5/11	7.5/11	7.5/11	7.5/11
Sub spindle	Chuck dia	mm	6"	6"	6"	6"	6"	6"	6"	6"	6"	6"
	Max.turning diameter	mm	180	180	180	180	180	180	180	180	180	180
	Max.turning bar diameter	mm	42	42	42	42	42	42	42	42	42	42
	Spindle nose	type	A2-5	A2-5	A2-5	A2-5	A2-5	A2-5	A2-5	A2-5	A2-5	A2-5
	Hole trough spindle	mm	55	55	55	55	55	55	55	55	55	55
	Spindle speed	rpm	6000	6000	6000	6000	6000	6000	6000	6000	6000	6000
	Spindle motor (cont/30min torque)	kw	5.5/7.5	5.5/7.5	5.5/7.5	5.5/7.5	5.5/7.5	5.5/7.5	5.5/7.5	5.5/7.5	5.5/7.5	5.5/7.5
Travel	X1 axis travel	mm	186.5	186.5	186.5	186.5	186.5	186.5	186.5	186.5	186.5	186.5
	X2 axis travel	mm	175	175	175	175	175	175	175	175	175	175
	X3 axis travel	mm	-	-	145	145	-	-	145	145	145	145
	Z1 axis travel	mm	600	600	600	600	600	600	600	600	600	600
	Z2 axis travel	mm	600	600	600	600	600	600	600	600	600	600
	Z3 axis travel	mm	590	590	590	590	590	590	590	590	590	590
	Y1 axis travel	mm	±45	±45	±45	±45	±45	±45	±45	±45	±45	±45
	Y2 axis travel	mm	-	-	-	-	±45	±45	±45	±45	±45	±45
	Tailstock travel	mm	-	-	100	100	-	-	100	100	100	100
	Quill taper	-	-	-	MT4	MT4	-	-	MT4	MT4	MT4	MT4
Motor	X1 axis rapid traverse	mm/min	24	24	24	24	24	24	24	24	24	24
	X2 axis rapid traverse	mm/min	24	24	24	24	24	24	24	24	24	24
	X3 axis rapid traverse	mm/min	24	24	24	24	24	24	24	24	24	24
	Z1 axis rapid traverse	mm/min	36	36	36	36	36	36	36	36	36	36
	Z2 axis rapid traverse	mm/min	36	36	36	36	36	36	36	36	36	36
	Z3 axis rapid traverse	mm/min	36	36	36	36	36	36	36	36	36	36
	Y1 axis rapid traverse	mm/min	18	18	18	18	18	18	18	18	18	18
	Y2 axis rapid traverse	mm/min	-	-	-	-	18	18	18	18	18	18
Turret	No.of tool station	set	16	16	16	16	16	16	16	16	16	16
	Tool size (square)	mm	20	20	20	20	20	20	20	20	20	20
	I.D.of boring bar holder	mm	25	25	25	25	25	25	25	25	25	25
	Live tool rotating speed	rpm	6000	6000	6000	6000	6000	6000	6000	6000	6000	6000
	Live tool rotating torque (cont / 60 min)	NM	17.7 / 23.6	17.7 / 23.6	17.7 / 23.6	17.7 / 23.6	17.7 / 23.6	17.7 / 23.6	17.7 / 23.6	17.7 / 23.6	17.7 / 23.6	17.7 / 23.6
	Live tool power	kW	3.7 / 5.5	3.7 / 5.5	3.7 / 5.5	3.7 / 5.5	3.7 / 5.5	3.7 / 5.5	3.7 / 5.5	3.7 / 5.5	3.7 / 5.5	3.7 / 5.5
Dimension	Coolant tank capacity	L	690	690	690	690	690	690	690	690	690	690
	Machine width	mm	3600	3600	3600	3600	3600	3600	3600	3600	3600	3600
	Machine depth	mm	1976	1976	1976	1976	1976	1976	1976	1976	1976	1976
	Machine height	mm	2175	2175	2175	2175	2175	2175	2175	2175	2175	2175
	Foundation dimension	mm	4135 x 3195	4135 x 3195	4135 x 3195	4135 x 3195	4135 x 3195	4135 x 3195	4135 x 3195	4135 x 3195	4135 x 3195	4135 x 3195
	Power supply	KVA	75	75	75	75	75	75	75	75	75	75

Standard Accessory

- Collet chuck (Main / Sub spindle)
- BMT 55 16 position power turret (T1 / T2)
- Fixed tool holder
- High-pressure central cooler motor-20 bar
- Part cather
- Part conveyor
- Chip conveyor
- Chip cart
- Fanuc 31i controller
- THK ballscrew
- THK linear Guideway
- Manual guide i
- Bar feeder interface
- Air blower
- Flow detection switch
- Hydraulic tailstock (only for type B/D/E)
- Coolant tank
- Auto lubrication system
- Coolant system
- Hydraulic system

Optional Accessory

- 3 Jaw chuck
- Driven tool holder
- Sub coolant tank
- Tool presetter (Main / Sub spindle)
- BMT 55 live tool
- Mitsubishi controller

TRAVELS

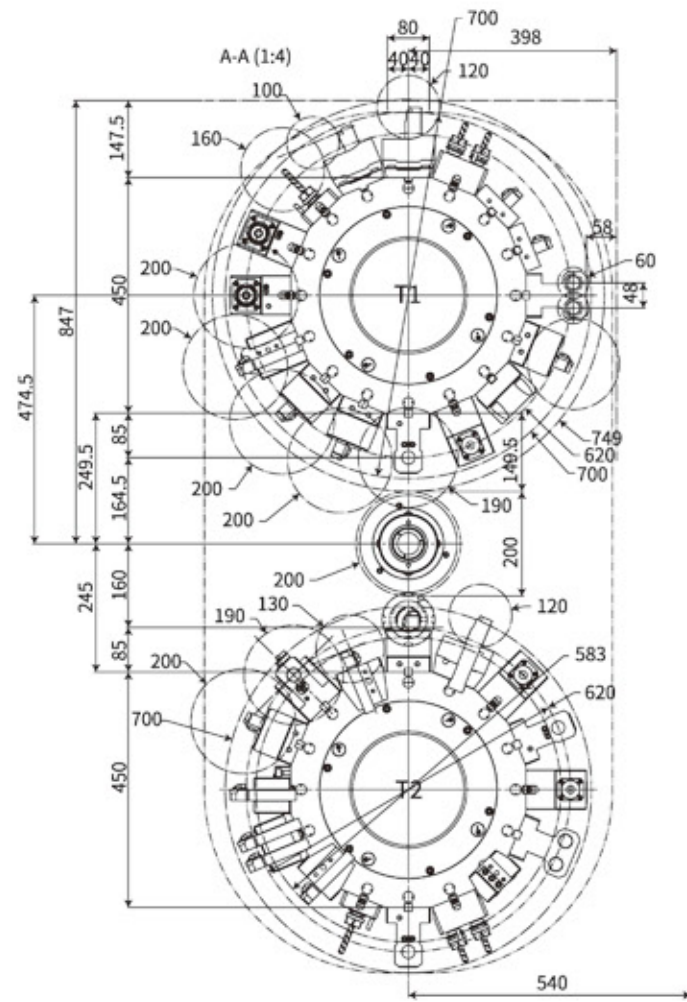
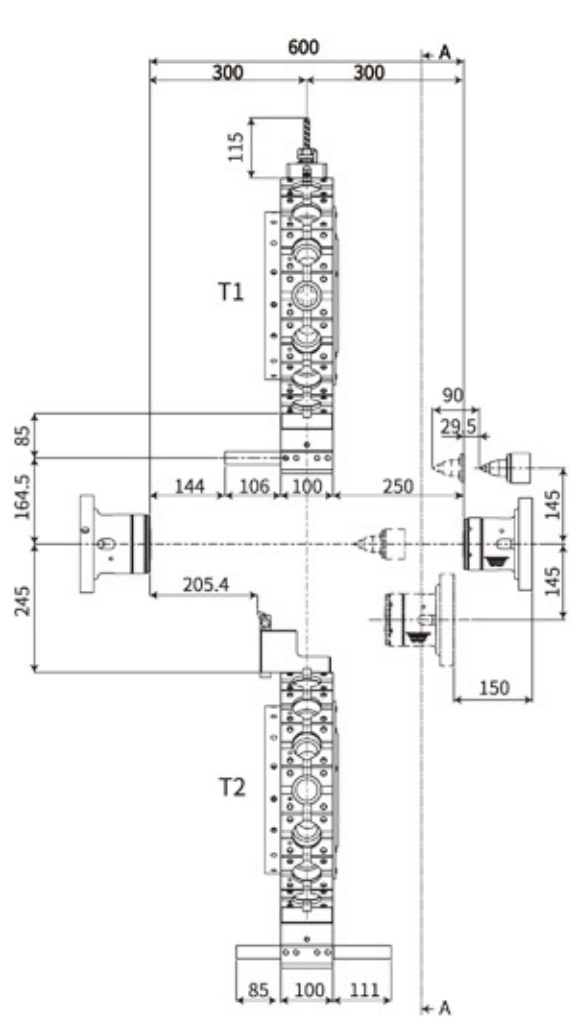
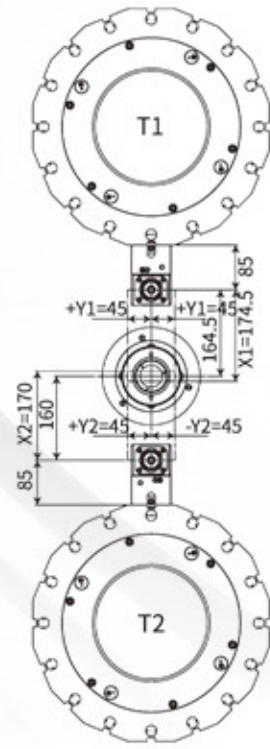

DIMENSIONS

